

DESIGN GUIDELINES FOR DOWNTOWN SALINA



United Life Building, 119 West Iron Avenue, 1929

LEE DISTRICT DESIGN REVIEW BOARD

January 2, 2008





**SALINA DOWNTOWN, INC.
HISTORIC SALINA DOWNTOWN
LEE DISTRICT**

Todd Davidson, SDI President

**DESIGN GUIDELINES
REVIEW COMMITTEE**

**Randy Graham
Troy Vancil
Kathryne Perney
John Millikin**

**LEE DISTRICT
DESIGN REVIEW BOARD**

**David Bieberly
Robert Hamman
Eloise Lynch
John Millikin
Kathryne Perney
John Nelson
Charles Renz**

STAFF

**Phyllis C. Klima, SDI Executive Director
Dean Andrew, Director of Planning
John Burger, Assistant Planner**

January 2, 2008

Old Salina City Hall, 1911-1969

Table of Contents

Introduction	1
1. Purpose of Design Guidelines	3
A. Design Objectives.....	3
B. Design Guidelines and Design Review.....	3
C. Uses and Benefits of Guidelines and Design Review.....	3
D. Components of the Design Guidelines.....	4
2. Historic Character of the Lee District	7
A. Lee District Boundary Map.....	7
B. History of Salina's Downtown District.....	9
C. Downtown Architectural Styles.....	11
3. Building Rehabilitation	15
A. Character-defining features.....	15
B. Storefronts.....	17
C. Windows and doors.....	18
D. Entries and Bulkheads.....	20
E. Cornices.....	21
F. Façade Materials.....	22
G. Design of Additions.....	23
4. Alterations & New Construction	25
A. Building Mass, Scale, and Form.....	26
B. Architectural Character.....	27
C. Color.....	31
D. Site Planning.....	31
E. Additions.....	32
5. Guidelines for Streetscapes	33
A. Signage.....	34
B. Awnings.....	37
C. Lighting.....	38
D. Utility and Mechanical Equipment.....	39
E. Parking Facilities.....	40
F. Landscaping.....	41
6. Guidelines for Demolition	42
7. Guidelines for Relocation	43
Appendices	
I. Design Review Matrix of Project Types	
II. Glossary of Definitions and Architectural Terms	
III. Secretary of Interior's Standards for Rehabilitation	
IV. National Park Service—Preservation Briefs	
V. Recommended Maintenance	

Introduction

This document presents design guidelines for the Lee District. They reflect the city's goals to promote economic development, enhance the image of the downtown and adapt and reuse historic resources. The guidelines neither dictate taste nor assure good design. Rather, they support the traditional qualities of the architecture and streetscape in the Lee District and provide a framework for sympathetic design.

Salina is fortunate to have a unique historic and cultural heritage. The historical figures and events that made Salina one of the prosperous communities in Central Kansas are long gone. However, they are recorded for posterity in our 19th century architecture. As such, these architectural resources serve as one of the most powerful and enduring tools for the education of future generations. The history of the city—its people, its industries, and its physical and economic growth—are tangible in the structures built during the nineteenth and early twentieth centuries.

While some significant buildings have been razed, an appreciable amount of the historic architectural fabric remains intact, particularly on Santa Fe Avenue. This enviable level of architectural integrity is a resource that should be promoted by the citizens and civic institutions of Salina as source of local pride.

The 2006 City of Salina Shared Vision Statement and Strategic Plan contains the following goal:

"Salina will be a town that is respectful of its heritage. Throughout Salina, the adaptive reuse of historic and architecturally significant buildings will be encouraged."

The values associated with the adaptive reuse of historic resources include:

- Providing a link with the past
- Establishing a distinct market image
- Quickly making a building available for occupancy
- Providing an attractive image
- Supporting heritage tourism strategies
- Reinforcing Downtown Salina's ambiance and civic pride

Part of what makes Salina's Downtown an interesting and attractive destination is the variety, detail, and quality of its architecture. The remarkable downtown architecture reflects quality craftsmanship, design and materials that survive in few other places. These buildings tell the cultural story of the skilled local builders, tradesmen and architects who built downtown with such pride and craftsmanship. Like any resource, the unique architectural heritage of Salina needs to be protected for future generations. The community recognizes the value of its architecture and the importance of devoting time and resources necessary to ensure the long-term protection and maintenance of downtown. Major changes in the materials and forms may result in a change of appearance, but they also result in a loss of historical information.

Downtown must also respond to an ever evolving market based economy. While the re-use of existing buildings is important, downtown must also adapt to current business use requirements to remain competitive in our local and regional economy.

Chapter 1. Purpose of Design Guidelines

A. Design Objectives

These design guidelines are based on several objectives for the Lee District:

- To develop an environment that encourages commerce, increases pedestrian activity, and contributes to the city's quality of life. To restore and preserve historic character when rehabilitating a building.
- To design new construction that will respect and be compatible with the scale, setback, and rhythm of existing buildings.
- To avoid demolition, if possible, by properly maintaining existing buildings.
- To ensure that public improvements complement district character.
- To promote visual harmony among buildings while allowing for variety and creative design.
- To develop a visually interesting and appealing environment for residents and visitors that recognizes downtown as the "visual" center of the community and a unique community asset.
- To preserve the historic character and architectural resources of downtown for future generations.

B. Design Guidelines and Design Review

These design guidelines address exterior features, particularly the character-defining features on facades and readily visible sides of buildings. These are NOT rules dictating a particular style. The guidelines offer flexibility for achieving design compatibility within the district. As the guidelines for the design review process, the guidelines emphasize rehabilitation over complete restoration. This approach is illustrated by descriptors such as repair, retain, maintain, and protect. The preference and emphasis is to repair original material rather than replace and to protect

the original upper façade features that contribute to a building's historical integrity. For new development, the overall relationship of the structure to the street and its surrounding area is reviewed. The building width, height, setback, floor levels, and pattern of repeated elements such as windows and doors is important in assuring that infill development harmonizes with the rhythm of the existing streetscape.

C. Uses and Benefits of Guidelines and Design Review.

These guidelines are based on design principles and preservation guidelines used in downtown districts across the country. These guidelines will be used in the review process for all renovation and new construction projects involving publicly visible work and for all demolition/relocation projects within the district. They also contain design guidelines for signs and other streetscape elements. Building owners, tenants and professional designers are encouraged to use these guidelines very early in the planning stages of projects to assure appropriateness and minimize design changes.

The guidelines will be helpful in:

- **Beginning a design.** Unnecessary guesswork as to the appropriateness or acceptability of a design will be avoided.
- **Working with an architect.** Knowing which types of design are encouraged will help owners to formulate clearer design requests.
- **Working with the Design Review Board.**

Because the guidelines establish a common language of communication, both building designers and the Design Review

Board will have a common reference point from which to evaluate a design.

What Design Guidelines Do:

- Restore, maintain, and reinforce district character;
- Guide and improve district growth and development;
- Protect property values by avoiding inappropriate design;
- Enhance and protect the visual integrity of the district;
- Provide the standard for objective design review (a level playing field) which applies equally to all;
- Serve as a common reference for architects, contractors, merchants, and property owners;
- Heighten public awareness of the value of historic structures and architecture;
- Provide the framework for making new construction and additions to historic structures as compatible as possible with the rest of the district; and
- Provide a pedestrian oriented downtown.

What Design Guidelines Do Not Do:

- Review ordinary maintenance or repair.
Ordinary maintenance or repair using identical materials to the existing does not require any review by the Design Review Board.
- Do not address the use of a property. Uses are part of the underlying zoning of the property which is controlled by the Zoning Ordinance that is administered by the City's Development Services Department.
- Do not address interior alterations not visible from the street.
- Require or force owners or tenants to make changes to a property, if they are not already making changes (Design review only occurs when an owner proposes a change or construction that requires a Certificate of Compatibility and/or a Building Permit.);

- Prohibit new construction or additions to historic buildings; or
- Dictate certain designs or design decisions.

The property value of every building in the district is influenced by adjacent buildings. All property owners' rights are protected from the adverse economic impact which could result from inappropriate actions through failure to adhere to the Lee District design guidelines.

D. Components of Design Guidelines

Chapter 3 focuses on the rehabilitation of existing buildings. Each of the remaining design guidelines in Chapters 4 and 5 contain the following four components;

1. Design Element

This category includes items such as streetscape, site planning, building materials, and secondary structures.

2. Policy Statement

This explains the Design Review Board's basic approach to treatment of the design element. This statement provides the basis for the more detailed design guidelines that follow it. In cases where special conditions in a specific project are such that the detailed design guidelines do not appear to address the situation, this general policy statement shall serve as the basis for determining the compatibility of the proposed work. **Policy statements are shown as large typeface statements.**

3. Background Information

This addresses issues typically associated with the specific design element. This may include technical information, as well as general rehabilitation theory that might be relevant to the topic at hand.

4. Design Guidelines

The design guideline statement is performance-oriented and describes the desired design treatment. The specific design guidelines are presented as **bold face** statements numbered under each policy statement.

4.1 Additional Information

Supplementary information related to the guidelines may include additional requirements, or provide further explanation. These sub-points are listed as bulleted statements.

4.3 Illustrations

Design guidelines are further explained through the use of photographs and illustrations. Examples given should not be considered the only appropriate options. In most instances, there are numerous possible solutions that meet the intention of the design guidelines, as well as the needs of the property owner.

The guidelines and illustrations used in this document do not represent all of the possible design solutions available. Just because an approach is not listed or illustrated does not mean that it is not acceptable. If there are any questions regarding the compatibility of a potential design solution, property owners and their professional contractors are encouraged to contact the City of Salina administrative staff assigned to the Design Review Board.

Example:

Policy : Maintain the line of building fronts in the block.

A. Site Planning

Structures in the Main Street District should contribute to a "strong wall" along the street. A new building should align at the front lot line and be built out to the full width of the parcel, to the side lot lines.

1. **Maintain or enhance the alignment of buildings at the sidewalk edge.**
 - Locate the front building wall at the sidewalk line when feasible.
 - Where a building must be set back from the sidewalk, use landscaping elements to define the sidewalk edge.



Chapter 2. Historic Character of the Lee District

A. Lee District Boundary Map

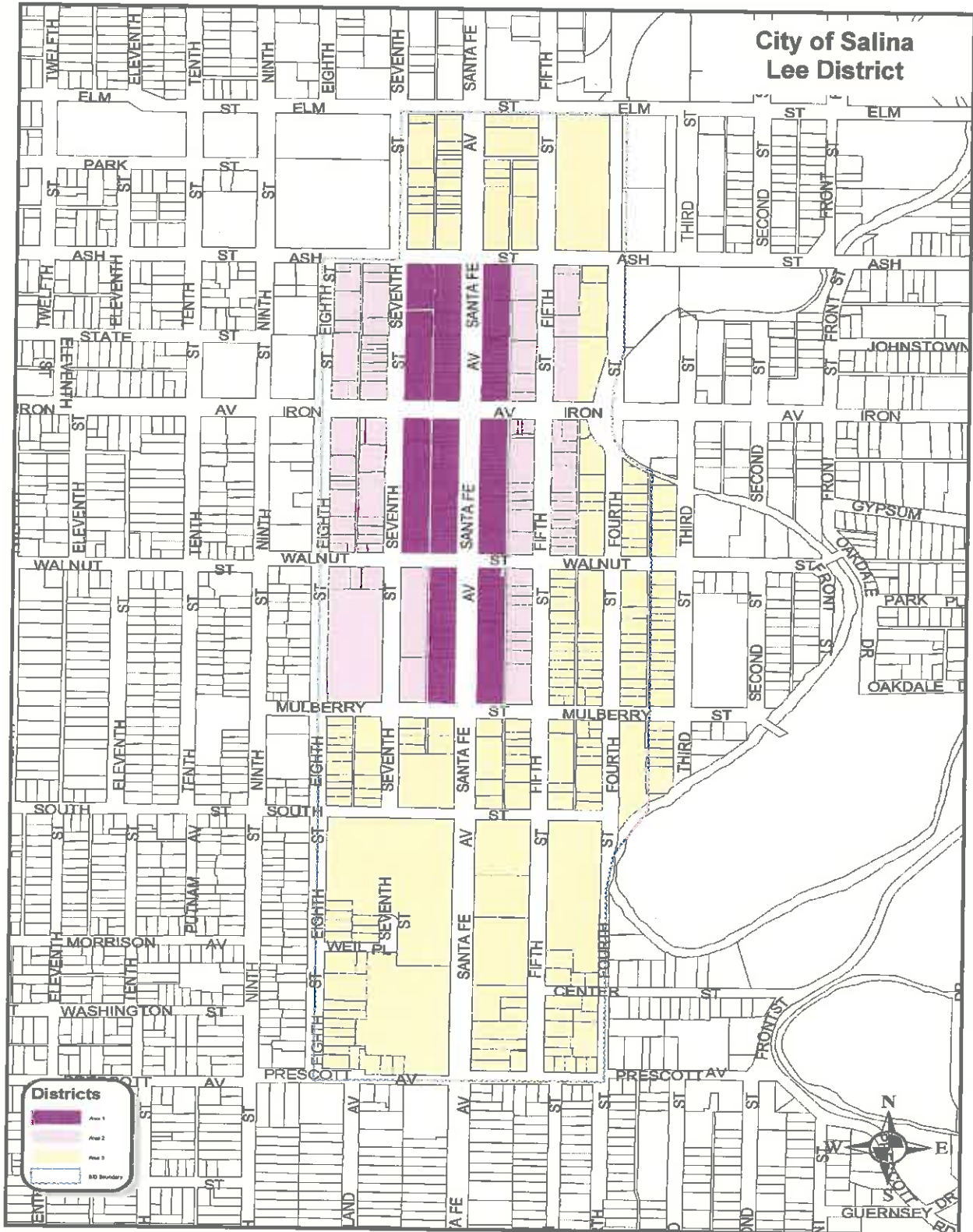

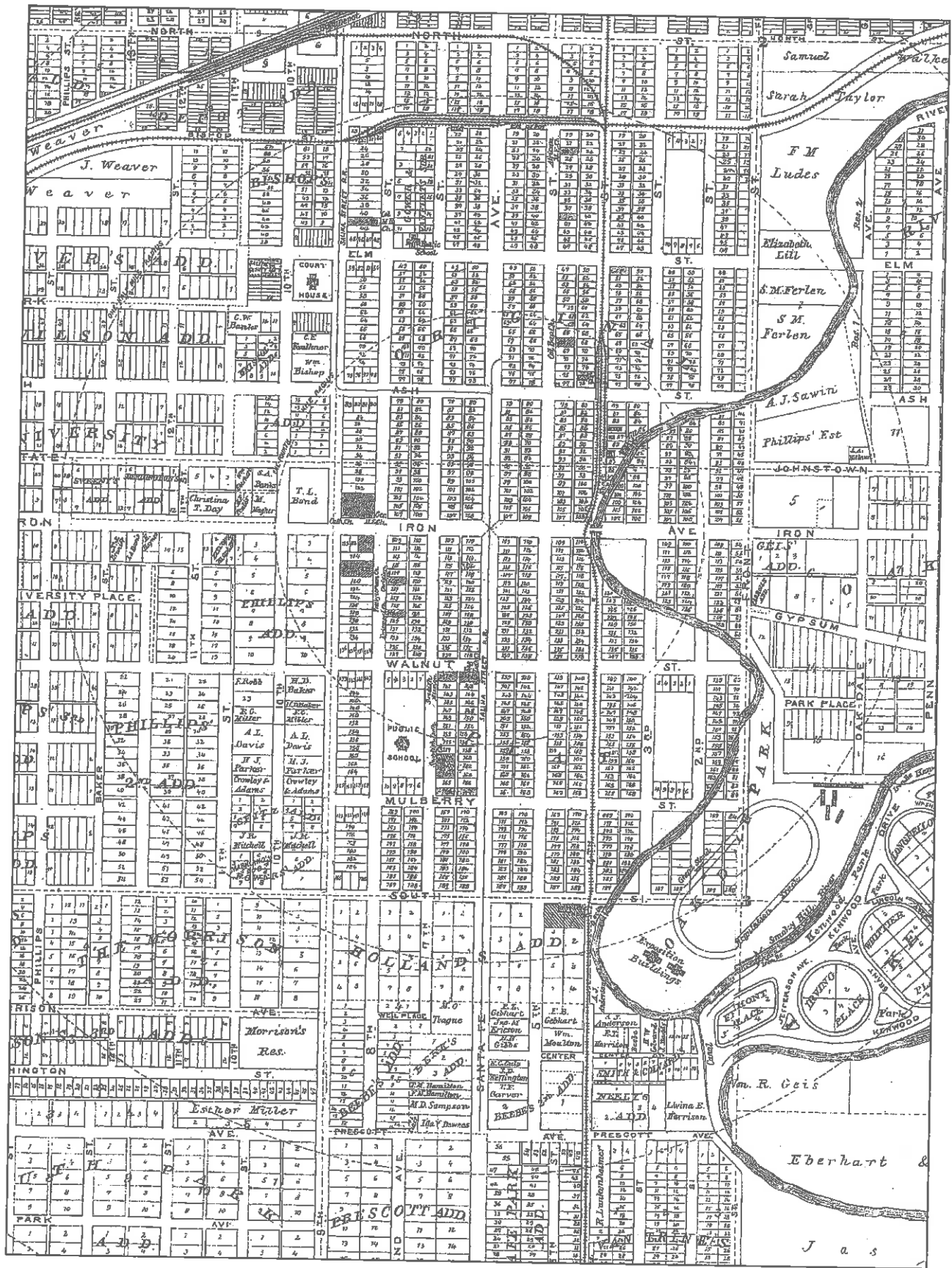

Portion of 1887 Salina Atlas

B. History of Salina's Downtown District

The City of Salina was originally laid out in 1858. Salina's town founders: William A. Phillips, Alexander M. Campbell, James Muir, David Phillips and Alexander C. Spilman laid out the town in rectangular blocks on the west side of the Smoky Hill River. All of the Original Townsite streets retain their original names. The town's plan is unique. Instead of a central town square, four blocks were set aside for public use grounds in each quarter of the town. The original School Park Block contained Roosevelt-Lincoln Middle-School, now Pioneer Presidents' Place. South Park once contained the former Washington High School.

Salina owes much of its heritage to the railroad. However, it is not a typical railroad town with the main commercial district fronting the tracks. The already-established business district in the north and south 100 blocks of Santa Fe Avenue did not relocate to the tracks nor was the town street system adjusted to accommodate the tracks. The commercial center and focus of the town remained at the intersection of Iron Avenue and Santa Fe Avenue.

Two disastrous fires in the downtown in 1871 and 1875, destroyed much of Salina's first business district, which was all wood frame construction. The town rebuilt in fire-proof brick, generally two-story structures with flat roofs that abutted the sidewalk line and shared party walls. These buildings sat on narrow 25 ft. by 120 ft. lots and featured cast-iron storefronts (also fire-proof) and decorative cornices and window surrounds. First floors were devoted to retail outlets; upper stories were offices or living space. The brick came from a number of local brick manufacturers, the most important of which was Salina Vitrified Brick Co., later known as Salina Brick and Tile.

None of these early buildings were architect-designed. They were typical examples of the vernacular commercial buildings built in big city commercial centers during this period using local brick and stock architectural design elements ordered from catalogs. Through the

years, the facades of these buildings were remodeled, often more than once, in order to maintain an up-to-date appearance. Thus a majority of Salina's historic commercial buildings were built in the 19th Century, but currently possess a 20th Century appearance.

The 20th Century commercial building design reflects evolution of building styles and available materials. The installation of larger plate glass window display areas, a wider facade and recessed entry and floating display islands, were made possible by new technologies; the use of new materials such as aluminum, stainless steel, pigmented structural glass, tinted or mirrored glass, glass block, neon, and marble. Many building renovations included special lighting, stylized lettering on signs and store design with a theme taken from a period of art history (i.e., Tudor, Spanish or Art Deco).

Salina's most influential architect, Charles W. Shaver, was particularly adept at Romantic Revival design in both commercial and residential structures. He designed the majority of Salina's exceptional commercial architecture between 1915 and 1940. His use of the Spanish Revival style and polychromatic terra cotta as a building material gives downtown Salina a unique character. Two outstanding examples of his work are the United Life Building, 119 W. Iron, built in 1929, and the former Fox-Watson (Now Stiefel) Theatre, 151 S. Santa Fe Avenue, built in 1931. The ten-story Art Deco United Life Building, the tallest building in Salina, features polychromatic terra cotta. The Stiefel Theatre was one of Kansas' grandest movie palaces in its heyday. Closed in 1987, the facility was restored for use as a community performing arts facility. The Stiefel Theatre reopened in 2003 thanks to a substantial gift from Milton Stiefel, owner of Salina's Stiefel Department Store.

After World War II, many of Salina's commercial buildings were remodeled again. Facade windows were eliminated, the

B. History of Salina's Downtown District (continued)

cornices removed and the entire facades clad in sheathing to give buildings a sleek "modern" appearance. Today, downtown Salina reflects a wide range of commercial architecture.

In 1958, local business and property owners acting through the Chamber of Commerce requested the City Commission take action to provide additional off-street parking spaces in the Downtown area. 45 properties (25 commercial and 20 residential) were eventually cleared. In 1962, six off-street parking lots were constructed on 7th Street and 5th Street. Pedestrian walkways were constructed which linked 5th and 7th Streets to Santa Fe. Public restrooms were constructed near these lots .

By 1983, the Downtown Merchants Association and the City of Salina created a 31 block Business Improvement District to manage the economic development and revitalization of downtown. Salina Downtown Inc. is the agency which manages these programs.

In 1985 the City launched a \$7 million Downtown Revitalization Program primarily focused on streetscape improvements. Seven new surface parking lots were constructed. Infrastructure improvements included the burying of utilities, decorative brick sidewalks, sidewalk planters and mid-block crosswalks. Four distinct plaza areas were created to link parking lots on 5th and 7th Streets to Santa Fe businesses and to provide open air public areas with seating, landscaping, recreational and performance space.

Downtown Salina was a Kansas Main Street City from 1989 through 2002. The program, which is administered by the Kansas Department of Commerce, combines historic preservation with downtown development to create a working growing and aesthetically pleasing business center. The Program advocates the preservation of Main Street Community's historic character.

In order to manage physical changes that take place in the downtown, building rehabilitation,

new construction and upgrading public improvements, a set of Design Guidelines were developed for use in the downtown area in 1995. The Guidelines have served an advisory basis since that time, for decisions by the Salina Downtown Board of Advisors and the Design Review Board.

In the fall of 2001, the City of Salina contracted with Denver-based Progressive Urban Management Associates (PUMA) to create a market-based plan for Downtown Salina. The plan established a multi-faceted development strategy for the downtown area based upon the central business district's unique niche and opportunities in the regional marketplace. Finalized in April 2002, the Market-Based Downtown Plan required realignment from a "preservation-based" Main Street approach to a more "market-based" economic development approach. The PUMA Report recommendations included specific opportunities for incentives for façade, signage, building restoration and the development of the Downtown.

In 2006, Salina Downtown Inc. formally recognized the pivotal role of entrepreneurs in downtown by requesting that the BID be renamed the Lee District. Henry D. Lee arrived in 1888 and became a major force in the community's commercial activity and economic growth. He founded H. D. Lee Mercantile Co., Lee Hardware Co., H.D. Lee Flour Mill and the Kansas Ice and Cold Storage Co. Lee Jeans®, his greatest legacy, started at 254 N Santa Fe, at the very north end of the district. His jeans are still one of the most popular blues jean brands in the world.



South Santa Fe Avenue looking north from Walnut c. 1974

C. Downtown Architectural Styles

Italianate

Beginning in the mid-nineteenth century, some architects reacted against the formal, classical architecture of the time and advocated more natural, picturesque styles. One of these styles was the Italianate. Inspiration for the Italianate style came from a variety of sources including country Italian villas and various urban Italian palaces. The style had a broad influence in the Midwest with one exception: late nineteenth-century commercial buildings. While the Italianate style was passing out of fashion by 1880, commercial buildings using elements of the style continued to be constructed into the 20th century. Mass-produced cornices, window hoods, and cast iron storefronts allowed merchants to ennoble plain buildings at an economical price.



148-150 S. Santa Fe Avenue

Common features:

- round or segmental-headed window and door openings with hood moldings
- windows often in pairs
- bracketed eaves
- deeply projecting cornice
- often a central pediment at roofline bearing name and date of building
- ornamented with panels, quoins, finials, and pilasters
- typical exterior materials: brick, stone, cast iron, pressed metal and wood



108-110 S. Santa Fe Avenue

Neoclassical Revival

Along with the Beaux Arts style, Neoclassical was largely influenced by several expositions held around the turn of the century, especially the World Colombian Exposition held in Chicago in 1893. Neoclassical Revival is based primarily on the Greek and, to a lesser extent, the Roman architectural orders. This style was extremely popular for bank buildings, and remained popular through the 1920s.

Common features:

- symmetrical facade
- cornice with dentils, modillions, and wide frieze band below
- pedimented porticos
- large classical columns rising two or more stories at entrances
- pilasters
- typical exterior materials: brick and stone



UMB Bank, 100 S. Santa Fe



Masonic Center, 336 S. Santa Fe Avenue

Vernacular Commercial

Usually between one and two stories tall, the vernacular commercial building is divided horizontally into two distinct bands. The first floor is more commonly transparent, so goods can be displayed, while the second story is usually reserved for storage space. One story examples have a bulkhead below the display window and a smaller band or transom above. The main door is frequently recessed.

These buildings have stone or brick facades. Ornamental detailing is simple, often limited to a decorative brick courses with stone insets or Spanish Revival parapets. These buildings lack distinctive detail, contrasting them with the revival styles that were also popular during this period.

Common features

- masonry construction
- small display windows
- bulkheads and transom lights
- recessed entry
- simple stepped cornices



149 S. 4th Street

Mission and Spanish Revival

Mission and Spanish Revival styles have been referred to as the California counterpart of the Colonial Revival in the Northeast. Spanish or Mediterranean Revival buildings draw inspiration from the entire history of Spanish architecture. Inspired by the themes of various World's Fairs held prior to World War I, especially the Panama-California Exposition of 1915, the style more precisely imitated Spanish prototypes. Also influential was the rise of Hollywood as the movie capital of the world during this time. Mission and Spanish Revival architecture is frequently found on movie theaters, early gas stations, and other commercial buildings. The Mission Style was loosely based on the early California missions, especially in the use of shaped parapets and arcades. Some Mission buildings also borrowed elements from the contemporary Craftsman and Prairie movements.

Common features:

- clay tile roofing
- curvilinear parapets
- plain string course outlining arches and parapets
- glazed tile surface ornamentation
- typical exterior materials: stucco and multi-color clay tiles



Woods Fashion Plaza, 157 N. 7th Street



200 S. Santa Fe Avenue

Factory / Warehouse

Both 19th and 20th Century factories and warehouses are included in this "style" which is characterized by brick construction, flat roofs, widely spaced windows and urban location. Loading docks often appear on the ground floor. Some warehouses have wholesale/retail space. Offices are usually limited to a small section of the building. Usually characterized by large, storefront-type windows.

Common features:

- ornamentation minimal
- few windows
- simple cornice or parapet
- decorative window surrounds and brickwork



248-254 N. Santa Fe Avenue, H.D. Lee Complex

Art Deco

The Art Deco style was a result of early twentieth century designers' wish to break from the past and express the fast-paced technological excitement of their own times. The ornamentation and forms used for these styles are visually linked to the Machine Age. Buildings in the Art Deco style are characterized by a linear, hard edge or angular composition often with a vertical emphasis and highlighted with stylized decoration. Art Deco is frequently found on certain types of commercial buildings such as gas stations, movie theaters, cafes, and drugstores – the later two often receiving a “modern” update from an earlier style. New government buildings of this era were often built in these new styles and were named Government Art Deco. Art Deco was popular in Salina from the late 1920s through the 1930s. Many Italianate buildings were given façade elements of the Art Deco style to modernize their appearance during this time.

Common features:

- vertical appearance
- low relief geometrical designs and stylized floral motifs
- typical exterior materials: structural pigmented glass, terra cotta, steel, concrete, stucco



107 & 111 N. Santa Fe Avenue



United Life Building, 119 W. Iron Avenue



City Water Treatment Plant, 401 S. 5th Street



Stiefel (Watson) Theatre, 151 S. Santa Fe Avenue

Chapter 3. Building Rehabilitation

These design guidelines apply to all properties in the Lee District. In general, properties are considered to be historic when they are over fifty years in age; retain architectural integrity to their original design; and are expressive of their period of historic significance.

These design guidelines provide a basis for making decisions about the appropriate treatment of historic resources and compatible new construction. They also serve as an educational

and planning tool for property owners and their design professionals who seek to make improvements. The design guidelines are written such that they can be used by the layperson to plan improvements. However, property owners are strongly encouraged to enlist the assistance of qualified design and planning professionals, including architects.

Policy: The character-defining features of a building should be preserved whenever possible.

A. Character-Defining Features

Character-defining features are those physical elements that collectively establish a sense of place, provide human scale and add rich detail to the street. Typical features include the historic facade material, a decorative cornice, vertically oriented upper story windows, larger first floor openings, and the trim around an opening.

1. Preserve character-defining features that are intact.

- The historic facade material, the trim around an opening and a historic cornice are among the character-defining features to preserve.
- Don't remove or damage character-defining features.
- Preserve intact features with appropriate maintenance techniques.
- Technical information for the preservation of historic materials is available at the City of Salina Development Services Department. See also Appendix IV. Preservation Briefs.
- When disassembly of an historic element is necessary, store building components in a safe place until they can be reinstalled.

2. Repair those features that are damaged.

- Use methods that will not harm the historic materials.
- Repair work is preferred over replacement.

3. Replace features that are missing or beyond repair.

- Reconstruct only those portions that are damaged beyond repair.
- Reconstruct the original element, based on adequate evidence, if possible. This is the strongly preferred option.
- If evidence for reconstructing an element is missing, a simplified interpretation of similar elements may be considered.
- Buildings may undergo alterations over time. New alterations often occur when original material is missing and new interpretations of traditional elements become necessary. New alterations should be planned so as to preserve the building's integrity.

4. Design an alteration to be compatible with the historic character of the property.

- Avoid alterations that would hinder the ability to interpret the historic significance of the original building.
- Alterations that seek to imply an earlier period than that of the building are inappropriate.

5. Avoid alterations that damage historic features.

For example, mounting a sign panel in a manner that causes decorative moldings to be damaged would be inappropriate.

Building Cornice



Upper facade



Storefront

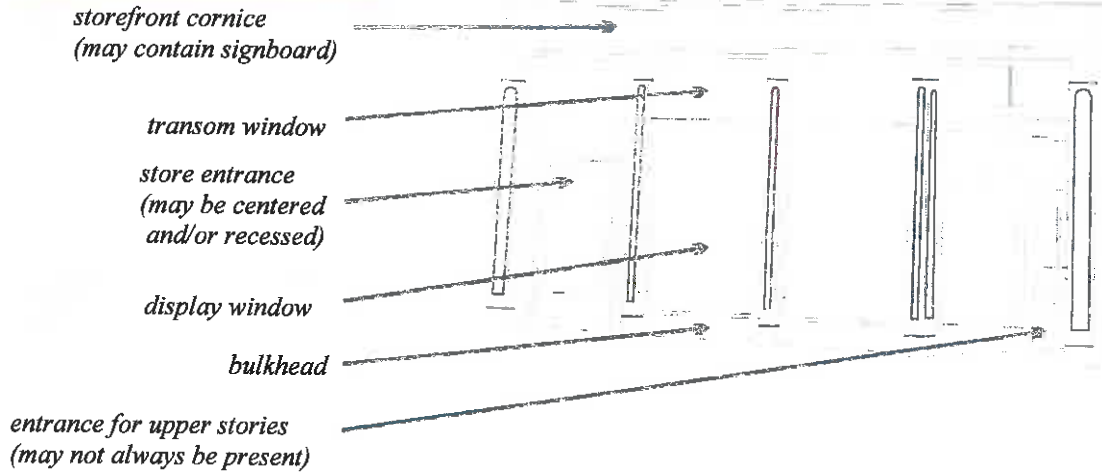

Typical Storefront Components

Policy: Maintain an original storefront and all of its character-defining features.

B. Storefronts

Many downtown storefronts have components seen traditionally on commercial buildings. The repetition of these standard elements create a visual unity on the street that should be preserved.

From the 1950s through the 1970s, commercial buildings in the historic downtown underwent a series of renovations in an attempt to update and “modernize” their appearance. The result was the installation of new materials over the original, or occasionally, entirely new storefront façades with new storefront materials. Fortunately, several examples have survived or have been repaired to reflect their original arrangement of large display windows over a bulkhead, recessed entrances, and large transom windows.

1. Original storefronts and their components shall be repaired or restored rather than replaced whenever possible.

2. Preserve the historic character of a storefront when it is intact.

These storefront elements shall include but not be limited to:

- **Display windows:** The main portion of glass on the storefront, where goods and services are displayed. This helps maintain pedestrians’ interest by providing views to goods and activities inside first floor windows
- **Transom:** The upper portion of the display glass, separated from the main display window by a frame.
- **Bulkhead:** Storefront base located beneath the display window.
- **Original Entry:** Usually set back from the sidewalk in a protected recess.
- **Upper story windows:** These usually have a vertical orientation, and appear to be less transparent than the larger expanse of display glass windows below.

- **Building Cornice :** A decorative band at the top of the building. A smaller storefront cornice may sometimes be found separating some floors (e.g., over the storefront and below the upper story windows).

- Elements that are missing, or deteriorated beyond repair, should be replaced with new materials that reflect the size, style and detail of the original.

3. If a storefront is altered, restoring it to the original design is encouraged.

- Historic photographs should be consulted when determining the original character of a storefront design.
- If evidence of the original design is missing, use a simplified interpretation of similar storefronts.
- Where an original storefront may have been altered early in the history of the building, it may have gained historic significance and should be preserved.

4. Alternative designs that are contemporary interpretations of traditional storefronts may be considered.

- Where the original is missing and no evidence of its character exists, an alternate design may be appropriate.
- An alternate storefront design should continue to convey the characteristics of typical storefronts, including the transparent character of the display window, recessed entry and cornice.
- Altering the size of an historic window, opening it or blocking it in with opaque materials is inappropriate.
- Greater flexibility in the treatment of a rear facade may be appropriate.
- Care should be taken to preserve a storefront on those buildings, which have traditional commercial storefronts on more than one facade.

Policy: Original windows and doors significantly affect the character of a structure and should be preserved.

C. Windows and Doors

Windows and doors are some of the most important character-defining features of a historic structure. They give scale to a building and provide visual interest to the composition of individual facades. Distinct window and door designs help define many historic building styles. Because window and door designs so significantly affect the character of a structure their treatment is very important consideration.

The size, shape and proportions of window and door openings are important features. The manner in which windows and doors are combined and arranged on a building face may be distinctly associated with a specific building style. All of these features are examples of elements in historic windows and door designs that should be preserved.

1. Maintain a historically significant storefront opening.

- The size and shape of an original window or door is an important characteristic that contributes to the integrity of an historic commercial building.
- Avoid altering the shape of window and door features.
- If these elements have already been altered, consider restoring them if their original condition can be determined.

2. Retain the original shape of the transom glass in an historic storefront.

- The upper glass band of a traditional storefront introduced light into the depths of a building. These bands are found on many historic storefronts, and they often align at the same height.
- The shape of the transom is important to the proportion of the storefront, and it should be

preserved in its historic configuration, whenever possible.

- If the original glass is missing, installing new glass is preferred. However, if the transom must be blocked out, use it as a sign panel or a decorative band, but be certain to retain the original proportions.
- Retain the original shape of the transom glass in an historic storefront. Removing or covering up the transom opening is inappropriate.

3. Preserve historic upper story windows.

- Historically, upper story windows had a vertical emphasis.
- The proportions of these windows contribute to the character of each commercial storefront.
- Don't block or infill them or alter their size.
- Consider restoring an original window opening which has been previously blocked in.
- Maintain the historic sash as well. Repair the sash, rather than replace it, whenever feasible.
- Preserve the character of divided light patterns on historic windows.

Policy: A new or replacement window or door should match the appearance of the original.

While replacing an entire window or door is discouraged, it may be necessary in some cases. Although wood was the most prevalent material, but also was utilized in early structures and is the most common. It is possible to consider alternative materials, if the resulting appearance matches the original as closely as possible. The substitute should also have a demonstrated durability in this climate.

4. When a window or door replacement is necessary, match the replacement to the original design as closely as possible.

- Preserve the original casing when feasible.
- Use the same material as that used historically.
- The use of vinyl and aluminum windows on upper stories is discouraged unless the window units match traditional windows in sash profile and appearance or are placed at the rear or sides of the structure.
- The use of tinted and reflective window glass is inappropriate on the main façades of historic buildings.
- If the original is double-hung, then the replacement windows should also be double-hung, or at a minimum, appear to be so. Match the original also in the number and position of glass panes.
- Very ornate windows or doors, that are not appropriate to the building's architectural style, are inappropriate.

5. Maintain the original ratio of window and storefront openings to solid wall.

- Significantly increasing (or decreasing) the ratio of glass may negatively affect the historic integrity of a structure.
- On traditional storefronts, first floors should be more transparent than upper floors.
- Upper floors should appear more solid than first floors.
- Avoid a blank wall appearance that does not provide interest to pedestrians.

- Large surfaces of glass are inappropriate on the upper floors and sides of commercial buildings.
- If necessary, divide large glass surfaces into smaller windows that are in scale with those seen traditionally.

6. New windows and doors may be considered on a secondary façade.

- New openings should be similar in location, size and type to those seen traditionally.
- Windows should be simple in shape, arrangement and detail.

7. Windows and doors should be finished with trim elements similar to those used traditionally.

- Divided lights should be formed from smaller mullions integral to the window. Pop-in muntins and mullions are inappropriate.

Policy: The original configuration of entries and bulkheads should be preserved if possible.

D. Entries and Bulkheads

The repetition of recessed entries provides a rhythm of shadows along the street, which helps establish a sense of scale and identifies business entrances. This pattern should be maintained.

A bulkhead or kickplate, was a popular feature of most commercial buildings. This feature should be preserved.

1. Maintain recessed entries where they are found.

- Restore the historic recessed entry if it has been altered.
- Avoid entries that are flush with the sidewalk.

2. Where entries are not recessed, maintain them in their original position when feasible.

- However, one also may need to comply with other code and ADA requirements, including door width, swing and construction.

3. Retain the bulkhead as a decorative panel.

- The kickplate, located below the display window, adds interesting detail to the streetscape and should be preserved.
- If the original bulkhead is covered with another material, consider exposing the original design.

4. If the original bulkhead is missing, develop a sympathetic replacement design.

- Wood and masonry are appropriate materials for replacements. Coordinate the color of the bulkhead with other trim elements on the building.

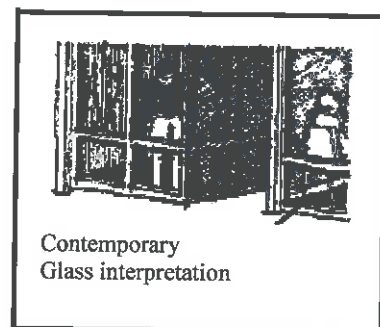
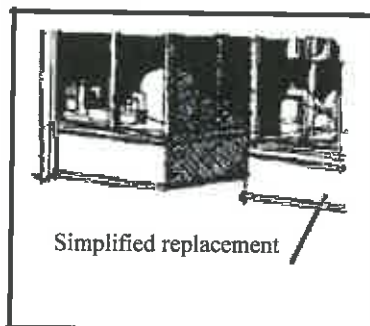
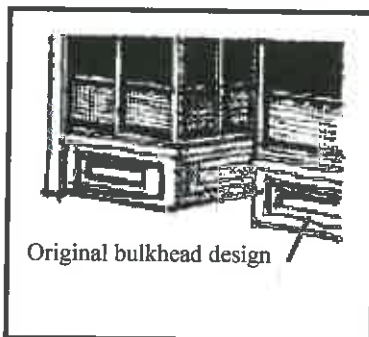

Retain the bulkhead as a decorative panel. If the original is missing, develop a sympathetic replacement design.



109 South Santa Fe

An acceptable solution was the use of ceramic mosaic tile which has been used to recreate the missing bulkhead in this location.

Policy: Preserve and maintain building cornices in their original configuration.

E. Cornices

Most historic commercial buildings have cornices to cap their facades. Their repetition and general alignment along a street contributes to the visual continuity on a block, and should be preserved.

1. Preserve the character of the cornice line.

- Most historic commercial buildings have cornices to cap their facades. Their repetition and general alignment along a street contributes to the visual continuity on a block.
- This may be a straight or stepped parapet.

2. Reconstruct a missing cornice when historic evidence is available.

- Use historic photographs to determine design details of an original cornice.
- The substitution of another old cornice for the original may be considered, provided that the substitute is similar to the original and the fact that it is not original is documented.

3. A simplified interpretation also is appropriate if evidence of the original is missing.

- Appropriate materials include stone, brick and stamped metal.

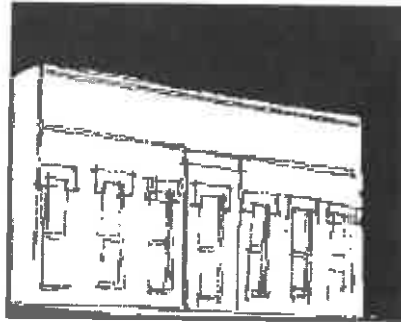

If the cornice is missing from a building, consider reconstructing it

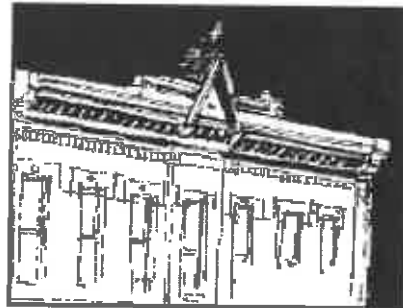

Reconstruct a missing cornice when Historic evidence is available.

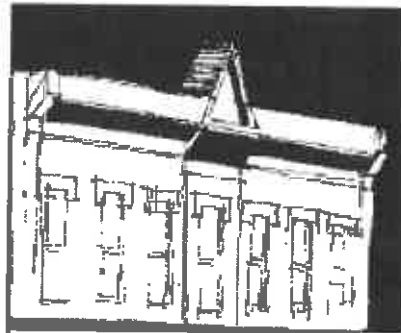

A simplified interpretation also is appropriate if evidence of the original is missing.

Policy: Preserve and maintain original façade materials.

F. Façade Materials

Original exterior building materials provide a sense of scale and texture and convey the work of skilled craftsmen. These original building materials should not be covered, damaged or removed unless other work being done is sensitive to the original character.

1. Historic building materials and craftsmanship add textural qualities, as well as visual continuity and character to the streetscape, and should be preserved.

- Brick, stone and wood have been the dominant building materials and masonry should be the first choice of materials to use.

2. Don't cover or obscure original façade materials.

- Covering of original facades not only conceals interesting detail, but also interrupts the visual continuity along the street.
- If the original material has been covered, expose it if feasible.
- Do not paint natural colored masonry.
- However, if masonry was painted

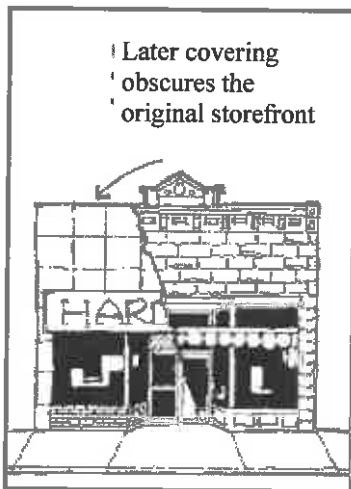

Don't cover or obscure original façade materials. If the original material has been covered, uncover if feasible.

historically, then it may be appropriate to repaint.

3. If material replacement is necessary, use materials similar to those employed historically.

- Masonry, either brick or stone, and wood were the primary wall material for most buildings. Wood and metal were used for window, door and storefront surrounds.
- Substitute materials may be used if they match the original in appearance, finish and profile as closely as is possible.

4. Protect historic material surfaces.

- Don't use harsh cleaning methods that can damage the finish of historic materials.
- Technical information for the treatment of historic material is available at the City Development Services Department. See also Appendix IV. Preservation Briefs for detailed methods of maintenance and repair.

5. Protect masonry from water deterioration.

- Provide proper drainage so water does not stand on flat surfaces or accumulate in decorative features.
- Provide a means to drain water away from foundations.
- Use a sealant, or clear coat, to protect masonry only when necessary. A sealant will prevent proper breathing and cause moisture to be trapped inside the masonry.

Policy: An addition should be compatible in scale, materials and character with the main building.

G. Design of Additions

Many buildings have experienced additions over time, as need for additional space occurred, particularly with a change in use. When planning a new addition to a historic structure, one should minimize the negative effects that may occur. While some destruction of original materials is almost always a part of constructing an addition, such loss should be minimized.

Two distinct types of additions should be considered: First, ground level additions, which involve expanding the footprint of a structure, may be considered. Such additions should be to the rear or side of a building, where it will have the least impact on the historic character of a building. There may only be limited opportunities for addition placement.

Second, an addition to the roof may be designed that is simple in character and set back substantially from the front plane of a building if appropriate. In addition, the materials, window size and alignment of elements on the addition should be similar to that of the existing structure.

- 1. An addition should not damage or obscure historically or architecturally important features.**
 - For example, loss or alteration of a cornice line should be avoided.
- 2. Design an addition such that the historic character of the original building can still be interpreted.**
 - A new addition that creates an appearance inconsistent with the historic character of the building is inappropriate. For example, an addition that is more ornate than the original building would be out of character.
 - An addition that seeks to imply an earlier period than that of the building is also inappropriate as it creates a false sense of history.
- 3. An addition should be subtly**

distinguishable from the historic building.

- An addition should be made distinguishable from the historic building, even in subtle ways, such that the character of the original can be interpreted.
- 4. An addition may be made to the rear or side of a building if it does the following:**
 - An addition should not create a false sense of history and should maintain the alignment of storefront elements, moldings, cornices and upper story windows—as seen on the existing building and its surrounding context.
 - 5. An addition may be made to the roof of a building if it does the following:**
 - An addition should be set back from a primary, character-defining facade, to preserve the perception of the historic scale of the building.

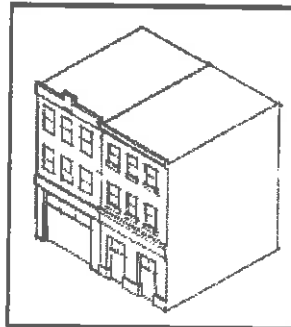

A new addition has been placed to the left side of an original three-story building.

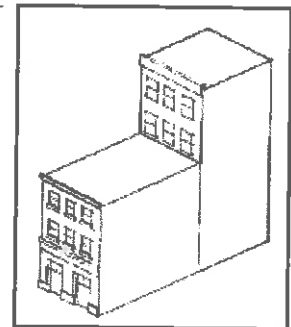

An addition has been placed to the rear of an original three-story building.

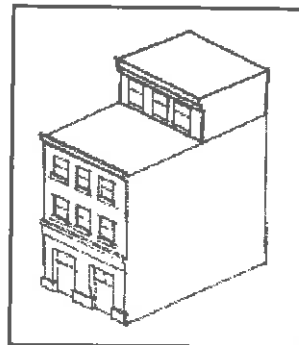

Here a roof addition has been set back from the front.

Chapter 4. Alterations and New Construction

While the Lee District has historic character, it is also a dynamic neighborhood in which existing buildings are altered and new buildings are constructed. Infill construction is encouraged on open lots in the District.

The design of a new building should not necessarily imitate historic buildings, but should be compatible with them. Creativity in design is especially encouraged when it also is compatible with the design objectives of the downtown.

New buildings should reinforce the basic character-defining features of the district. Such features include the way in which a building is located on its site, the manner in which it faces the street, its materials and the general alignment of architectural elements and details along a block. Arranging these design variables to be similar to those in the area creates visual compatibility.

The principal façade (front) and street related elevations of proposed new buildings will be more carefully reviewed than other facades. New construction facades should be consistent with the existing District buildings in terms of height, scale, rhythm, and other design characteristics.

New construction should not appear old. The intent of Lee district is not to "freeze" an area in time, but rather to encourage new buildings which fit contextually within the district. New construction should not attempt to replicate the old or to introduce a false "historic" appearance. For most new construction projects, the best approach is to **HARMONIZE** with and reinforce the context of existing buildings. The purpose of the design guidelines is to encourage new buildings that complement the best of the existing environment.

The dominant character should be pedestrian-friendly with an active street edge. New buildings should include the following key design aspects to help maintain that established District character:

- Buildings aligned at the sidewalk edge;
- Two-story traditional commercial buildings (some buildings reach greater heights);
- Masonry construction dominates;
- Transparent ground floor with smaller windows into predominantly solid upper floors;
- Flat-roof (low slope) buildings;
- Additions are compatible in size, form, materials, and design;
- Maintain traditional mass, size, form, and building materials;
- To design commercial buildings with storefront elements similar to those seen traditionally (e.g., recessed entry, display windows, bulkhead, transom windows, storefront cornices, upper cornices, and vertically oriented upper-story windows)
- To promote friendly, walkable streets.



Building materials should be compatible with materials of existing buildings.

Policy: A building should appear similar in scale to traditional commercial buildings

A. Building Mass, Scale and Form

Building heights generally vary in the Lee District from one to four stories, yet there is a strong sense of similarity in scale. A variety in building heights is appropriate; however, the dominant scale of two stories should be maintained. New construction should blend in the streetscape and not stand out. Buildings used as infill should be similar in height to adjacent buildings, and of a height of no more than 15 feet higher than the tallest adjacent building, and should not overpower the character of the District. The infill buildings should line up with existing setbacks, reinforce the established horizontal lines of the elevations, and maintain the rhythm in the single lot widths of new buildings.

1. Maintain the established building scale in height.

- Develop a primary façade that is in scale and aligns with surrounding traditional buildings.
- Consider stepping the mass of a tall building down to a lower height as it approaches surrounding buildings.

2. Buildings should appear similar in width to those historically in the block.

- Facades of large buildings should reflect the 25 ft. storefront bays to be in scale to traditional buildings.
- When a larger building is divided into bays, these should be expressed three-dimensionally throughout the entire building façade.

3. Floor-to-floor heights should appear to be similar to those seen in adjacent buildings.

- In particular, those windows in a building should appear similar in height to those seen in adjacent buildings.

4. A building should maintain the alignment of horizontal elements along the block.

- This alignment occurs because many of the buildings are similar in height.
- Window sills, moldings, and cornices are among those elements that may be seen to align.

5. Where appropriate, consider dividing larger buildings into bays that are similar in scale to buildings seen historically.

- If a larger building is divided into bays these should be expressed three dimensionally, throughout the entire building.
- When considering a tall structure, the alignment of building elements is particularly important. Although a new building may tower above the surrounding buildings, the first stories should visually relate to the surrounding historic context.

One of the most prominent unifying elements of a downtown district is the similarity in building form. Commercial buildings are simple rectangular solids, deeper than they are wide. This characteristic is important and should be continued.

6. Rectangular forms should be dominant on commercial facades.

- Rectangular forms should be vertically oriented.
- The façade should appear as predominantly flat, with any decorative elements and projecting or setback “articulations” appearing to be subordinate to the dominant form.

7. Use flat roof lines as the dominant roof form.

- Parapets of side facades should step down towards the rear of the building.

Policy: Building materials should be visually compatible with the predominate materials of the downtown area

B. Architectural Character

New materials should be appropriate to the scale, durability, color, and texture of the predominate materials in the area.

1. Material should appear similar to those used traditionally.

- Brick was the traditional material and is preferred.
- Wood and metal were used for windows, door and storefront surrounds and should be continued.
- New materials will be considered on a case-by-case basis. If used, they should appear similar to those used traditionally and should be detailed to provide human scale.
- New materials should have a demonstrated durability. Some new materials are susceptible to weather and do not last as long as brick.
- Existing metal should be maintained. If it needs to be stripped, use a chemical paint designed for that purpose, not dry grit blasting.
- Preserve cast iron by maintaining and restoring original cast iron columns and pilasters. Do not conceal or obscure original cast iron columns or pilasters.
- When it is necessary to replace brick, it should match in color and size to the original, if at all possible.
- Unless necessary to protect the surface, masonry should be left unpainted.
- Previously painted surfaces should be repainted rather than chemically cleaned. Repoint mortar, if necessary, before painting brick.
- Sometimes missing details and appropriate materials can be recreated with a one-dimensional paint scheme.
- Brick and other masonry should not be coated with silicone-based water sealants. Water sealants or water repellents generally have the effect of

keeping interior moisture from evaporating through the walls and thereby damaging the brick and mortar.

- Masonry should not be covered with stucco, wood siding, aluminum or other artificial materials.

It is important that buildings be compatible with the surrounding traditional commercial context, however new buildings should not imitate older building styles.

2. Maintain the distinction between the street level and upper floors.

- The first floor of the primary façade should be predominantly transparent glass, not tinted.
- A minimum of sixty-five percent of a street level façade of all buildings (except civic and institutional) should be windows, doors, display areas, or similar architectural features.
- Consider using storefronts, decorative surfaces or other features that provide visual interest to pedestrians. Avoid large expanses of featureless wall surface at the street level. These will discourage pedestrian activity in the District.
- Upper floors should be perceived as more opaque than the lower floors.
- Express the traditional distinction in floor heights between street levels through detailing, material, and fenestrations. The presence of a belt course is an important feature.

3. Upper-story windows with vertical emphasis are encouraged.

- A typical, upper-story window is twice as tall as it is wide. Upper story windows should relate to historic window proportions.
- Windows, lintels, and their trim elements should align with those on adjacent historic buildings.

Policy: Building materials should be visually compatible with the predominate materials of the downtown area (continued)

4. Orient the primary entrance of a building toward the street.

- A building should have a clearly defined primary entrance. For most commercial buildings, this should be a recessed entryway.
- Original entrances should be maintained, restored, or replaced (do not enclose, cover, or alter) including the design, material, depth, and placement.
- Aluminum replacement doors and storefronts should be made compatible by painting a dark color.
- Do not use doors decorated with molding, cross bucks, or window grills. Do not use solid wood doors in storefronts, unless original.
- If original design of a door is unknown, replace with a plain wood door with plain glazing (glass area), as opposed to solid wood doors, decorative doors, or any kind of period reproduction door.
- New entrance openings should not be added to storefronts. If an additional entrance is required by codes, place it on the rear or side façade and not on the main façade.
- Doors added to storefronts should be replaced with doors to match the original in design and materials.

5. Maintain all aspects of the storefront (including doors, windows, and details) when possible.

- Preserve existing original storefront elements (windows, transoms, lintels, sills, hoods, bulkheads, cornices, and parapets) by maintaining or restoring, do not remove or alter. It is better to repair than replace deteriorated storefront features. Covering or removing significant elements such as transoms, panels below store windows, or original doors results in a substantial loss of historic character.

- Use a traditional storefront arrangement with features, materials, and proportions typical of similar structures of the same (not earlier or later) architectural style or period when the original design and features can not be determined. Storefront material should be simple.
- Do not allow storefront design to stray out of its natural place within the façade. Generally, there should be more glass and fewer walls at the storefront level, balanced by more walls and less glass on the upper façade.
- Display windows which are new, should match the original in location, design, size, configuration, and materials.
- Display windows which are missing and the original design is unknown, should be replaced with traditionally scaled windows. Traditionally scaled windows have large glass lights and few structural divisions to maintain a traditional transparent storefront appearance. If aluminum frame windows are used, utilize dark anodized or baked enamel finishes.
- When replacing missing or damaged features and based on historic evidence such as photographs or "ghosts" marking or cornice locations or through newspaper or photographic research, base new building features from a similar building of the same design, use simple (but to scale) decoration.
- Windows which are not original should not be added.
- Windows should be repaired rather than replaced, but if replacement is necessary the replacement windows should fill the entire original opening and duplicate the original pattern, including dimensions, number and arrangements of lights in each sash, materials, and detailing. If aluminum framed windows are used, use dark anodized or baked enamel finishes.

Policy: Building materials should be visually compatible with the predominate materials of the downtown area (continued)

- Storm windows should be painted to match the color of the window sash and window shape should be duplicated. It may be desirable, on the front of building, to install storm windows inside where they will not be seen. Storm windows use full view or sash proportionate, blind stop type of wood or aluminum with anodized or baked-on enamel finish.
- New display windows should match the original in location, design, size, configuration and materials.
- New windows should not have snap on or flush muntins. True divided muntins are preferred over these types of muntins. Properly sized muntins permanently attached to windows are acceptable.
- Decorative glass windows which are original should be preserved in their original location, size, and design and with their original materials and glass pattern.
- On the interior, should the building's ceiling interfere with the transom space, recess ceiling space slightly away from the transom, or paint rear (interior) of the transom black.
- Windows can not be blocked or filled in.
- Metal flashing should be used with new roof materials extending along the brick walls to protect against leaks.
- Buildings with flat roofs should have cornices or decorative bands to "cap" the façade.
- Replacement gutters and downspouts should not result in the removal of significant architectural features on the building.
- Gutters and downspouts either of boxed or built-in type should be repaired rather than replaced if possible.

7. Foundations

- Preserve (maintain or restore, not enclose or alter) original foundation materials and design -- whether solid or pier, brick, stucco or stone, etc.
- Foundations should not be concealed with concrete block, plywood panels, corrugated metal, or other non-original materials.

6. Roofs, Cornices, & Gutters

Roofs should be retained in their original shape and pitch, with original features, and, if possible, with original roof materials.

- New roofs covered with modern rolled composition, asphalt materials, or rubber membrane are appropriate. The installation of a higher pitched roof to improve water runoff is acceptable as long as the new roof is not visible on the primary elevation and is constructed below the roof parapet wall.
- Do not use mansard roof with wooden shingles.

Policy: The street level of a building should be pedestrian friendly.

The Lee District should continue to develop as a pedestrian-oriented environment. Streets, sidewalks, and alleys should encourage walking, sitting and other outdoor activities. Buildings also should be visually interesting to invite exploration by pedestrians.

Existing pedestrian routes should be enhanced. A building should express human scale through material and forms that were used traditionally. This is important because buildings are experienced at close proximity by the pedestrian.

8. Develop the ground floor level to encourage pedestrian activity.

- A storefront should be used on the primary façade of a building.
- On a secondary facades, alternative methods of creating pedestrian interest should be utilized. Consider the following:
 - ◊A storefront
 - ◊Display case
 - ◊Public art
 - ◊Landscaping
 - ◊Decorative wall surfaces.

- Include traditional elements such as display windows, bulkheads and transoms on commercial storefront.
- Avoid a blank wall or vacant lot appearance.



Storefront has been redeveloped and is pedestrian friendly.

Policy: Minimize the visual impact of balconies and roof decks as seen from the street.

Roof gardens, decks, and accessory structures can visually impact the design integrity of the building on which they are located, their visual impacts should be minimized.

9. Set activities back such that they are not visible from the sidewalk across the street.

- This includes potted plants, umbrellas, and tables.
- Roof terrace railings and furniture should be placed well behind the parapet.

10. Avoid clutter on roofs that will be visible from the public's view.

- Mechanical equipment shall not be visible from the public's view.

11. A roof garden, deck, or accessory structure should be compatible with the building on which it is located.

- This includes design, materials, scale, proportion, and color.
- A roof garden, deck, or accessory structure should not damage, destroy, or overshadow the character-defining features of the building on which it is located.

Policy: Use colors to create a coordinated color scheme for a building.

C. Color

Downtown buildings contain a variety of colors in elements such as upper facades, storefronts, sign, and awnings. The introduction and use of colors should not be restricted but it is encouraged that colors complement each building and its neighbors. There is **not** a specific color palette for the Lee District.

A. The façade should “read” as a single composition.

- Paint colors on storefronts, trim, and upper-story openings should be related to the overall color of the building as should

added elements such as signs and awnings.

- In many cases these will be colors that complement or harmonize with the overall brick colors found on upper facades.

B. Use color schemes that are simple.

- Using one base color for the building is preferred.
- Using only one or two accent colors is also encouraged, although precedent does exist for using more than two colors in some situations.
- The use of contrasting colors to highlight architectural details or storefronts and upper facades is encouraged.

Policy: Maintain the line of building fronts in the block.

D. Site Planning

Structures in the Lee District should contribute to a “strong wall” along the street. A new building should align at the front lot line and be built out to the full width of the parcel, to the side lot lines.

1. Maintain or enhance the alignment of buildings at the sidewalk edge.

- Locate the front building wall at the sidewalk line when feasible.
- Where a building does set back from the sidewalk, use landscape elements to define the sidewalk edge.

2. Orient the primary entrance of a building toward the street.

- A building should have a clearly defined primary entrance. For most commercial buildings, this should be recessed entryway.
- A secondary public entrance to commercial spaces is also encouraged on a large building.

3. Rear entrances and side elevations.

- Preserve original windows, doors, and architectural detailing on rear and side elevations.
- Rear and side entrances can be enhanced by adding simple signage, awnings, and lighting that is related to those of the front elevation.
- New windows and doors may be added when needed if in keeping with the size, design, materials, proportions, and location of the originals. Follow guidelines for windows and doors for new openings on the rear and side elevations.
- Locate any necessary exterior staircases, balconies, elevator shafts, and additions on rear elevations, whenever possible.



Maintain the alignment of buildings at the sidewalk edge.

Policy: Minimize the visual aspects of an addition.

E. Additions

There are three different types of additions that may be constructed. The ground-level addition is the first way to do an addition that involves expanding the footprint of the structure. This addition should be to the rear or side of a building where it will have the least impact on the character of a building.

The next option of constructing an addition is to the roof that can be simple and set back from the front of the building. Materials, window sizes, and alignment of trim elements on the addition should be compatible to those of the existing structure.

The third option is to design an addition within the wall plane of the existing building, which should be considered on a case-by-case basis. This is difficult and requires care to respect the relationship of the building to the street. Such an addition should provide a visual distinction between the existing building and its addition which can be done with the use of a storefront cornice element or a subtle change in building materials.

1. An addition should be compatible in scale, material, and character with the main building.

- An addition should relate to the building in mass, scale, and form. It should be designed to remain subordinate to the main structure.
- An addition to the front of a building is inappropriate.

2. An addition may be made to the roof of a building if it does the following:

- An addition should be set back from the primary façade, to preserve the perception of the historic scale of the building.
- Its design should be modest in character, so it will not attract attention from the historic façade.
- The addition should be distinguished as new, albeit in a subtle way.

3. In limited circumstances, an addition may be made to the roof of a building and not be set back from character-defining façades, if it does the following:

- An addition should be distinguished from the existing building. A change in material or a decorative band can be considered to accomplish this.
- An addition should maintain the alignment of storefront elements, molding, cornices, and upper-story windows that exist on the main part of the building.
- The addition should also be compatible in scale, texture, and materials with the original.

4. An addition should not damage or obscure architecturally important features.

- Loss or alteration of a cornice line should be avoided, for example.
- Additions should respond architecturally to adjacent buildings in general and to the building they are a part of in particular. They should blend in by using similar materials, shape, and rhythm and proportion of openings.
- If the original building is architecturally significant, the addition should take a respectful "back seat". The addition should not overpower the original. An addition may be taller than the original building if site consideration and design still allow the old building to remain dominant.
- In general, additions should follow the basic guidelines for new construction. They should appear contemporary but in context with the original. The addition should be sympathetic but not imitative in design.

Chapter 5. Guidelines for Streetscapes

This section concerns the relationship of buildings or groups of buildings to the setting in which they are found. Site features need to be considered as an important part of any project. Site elements can include driveways, walkways, water fountains, lighting, fences, walls, signs, and trees.

In an historic setting, it is particularly important to preserve and restore features of the built environment, such as street or sidewalk paving, landscaping, and street lighting or signage. These features are indicative of the character of the area, and make an important statement about design.

Whether considering the entire Lee District or an individual structure, these features which show age and historic character should be preserved. These guidelines will apply only to areas visible, either private or public, from public rights-of way.

Historic architecture is not the only element that helps convey the character of a district. The relationship between a building and its site, landscape features, and other elements produce a distinctive image for the district. The distinguishing original qualities or character of a street, site, and its environment should not be destroyed. For example the removal or alteration of any historic material or distinctive architectural or environmental features should be avoided if at all possible. If removal or alteration of historical materials can not be avoided, i.e. landscape features such as stone walls, steps, etc., then these features shall be reused in a like manner elsewhere on the property.

Under the 1985 Downtown Revitalization Program, the City of Salina constructed numerous streetscape elements that enhanced and made the core Downtown area more attractive and accessible. These

improvements included, among others, the burying of utilities, decorative brick sidewalks, planters, street lights, plazas and various other amenities that in total made the area more attractive to pedestrians and various outdoor events.

In considering improvements to the existing streetscape, the Design Review Board should be guided by the following principles:

- 1) The historic character of the District shall be maintained and enhanced;
- 2) The safety and security of pedestrians and vehicles shall be provided;
- 3) A pedestrian oriented downtown shall be promoted;
- 4) Streetscape elements shall be compatible and continue to be in scale with the existing streetscape; and
- 5) The District shall be a place that encourages people to gather and meet.

Improvements to the public areas of the district (except for routine maintenance) are managed by the Salina Downtown organization. It is the Design Review Board's responsibility to examine improvements on private properties and how they relate to the Downtown Revitalization Element and the principles laid out by the 2002 PUMA plan.

Policy : Design a sign to be in balance with the overall character of the downtown area.

A. Signage

A sign typically serves two functions: first, to attract attention, and second to convey information, essentially identifying the business or services offered within. If it is designed well, the building front alone can serve the attention-getting function, allowing the sign to focus on conveying information in a well-conceived manner. All new signs should be developed with the overall context of the building and of the area in mind.

Signs that are historically important and retain or recreate integrity should be maintained. Sandwich boards are encouraged, but should not obstruct pedestrian traffic. All signs must also follow the regulations regarding signs in the Salina Zoning Ordinance.

1. Consider the building front as part of an overall sign program.

- Coordinate a sign within the overall façade composition.
- A sign should be proportional to the building, so it does not dominate the appearance of a building.
- Develop a master sign plan for the entire building to be used to guide individual sign design decisions.
- Signs should be integral with the building's architecture.

2. Preserve historic signs where they exist, when feasible.

3. A sign should be subordinate to the overall building composition.

- A sign should appear to be in scale with the façade and be to pedestrian scale.
- Locate a sign on a building such that it will emphasize elements of the façade and does not cover them.

- Mount a sign to fit within existing architectural features. Use the shape of the sign to help reinforce the horizontal lines of moldings and transoms seen along the street.



Historic sign, 157 N. 7th Street Wood Fashion Plaza



A sign that visually overpowers the building or obscures significant architectural features is in appropriate.

Policy : Design a sign to be in balance with the overall character of the downtown area (continued)

- 4. Freestanding or pole mounted signs may be considered.**
 - Freestanding or pole mounted signs may be considered in areas where the primary structure or business is set back from the street.
- 5. A flush-mounted wall sign will be considered depending on the building façade.**
 - When feasible, place a wall sign such that it aligns with others on the block.
 - When planning a wall sign, determine if decorative moldings exist that could define a "sign panel." If so, locate a flush-mounted sign such that it fits within a panel formed by moldings or transom panels. When mounted on a building with historic elements, a sign should not obscure significant façade features.
- 6. A window and/or awning sign may be considered.**
 - A window sign may not cover more than approximately thirty-three (33%) percent of the total window area.
 - Signs may be painted on the glass or hung just inside a window.
 - Signs should not significantly reduce storefront transparency or overpower the architecture of the building.
 - An awning sign or logo should be located on the valance of the awning and not on the sloped portion.
- 7. A projecting sign is encouraged.**
 - A small projecting signs should be locate near the business entrance, just above the door or to the side of it.
 - A large projecting sign should be mounted higher, and centered on the façade or positioned at the corner.
 - A projecting sign is easier for a pedestrian to read than other sign type and is encouraged.
- 8. A directory sign may be considered.**
 - Group small, individual signs on a single panel as a directory to make them easier to locate.
- 9. Use colors for the sign that are compatible with those of the building front.**
 - Limit the number of colors used on a sign.
- 10. Sign materials should be compatible with that of the building façade.**
 - The use of historic sign materials is encouraged: finished, carved, painted or sandblasted wood, metal, glass, gold leaf, brass and copper letters, not unfinished plywood or plastic.
 - Unfinished materials, including unpainted wood, are discouraged because they are out of character with the context.
 - Highly reflective materials that will be difficult to read are inappropriate.
 - Painted signs on blank walls were common historically and may be considered.
- 11. A simple sign design is preferred.**
 - Typefaces that are in keeping with those seen in the area traditionally are encouraged. Select letter styles and sizes that will be compatible with the building front.
 - Avoid hard-to-read or overly intricate typeface styles.
 - Signs are most successful when they work with, not against the architecture and are proportioned to fit the building.
 - Signs should capitalize on the special character of the building and the District.



Compatible projecting sign.

Policy : Design a sign to be in balance with the overall character of the downtown area (continued).

12. Lighting that is directed at a sign from an external, shielded lamp, is preferred.

- A warm light, similar to daylight, is preferred.

13. If internal illumination is used, it should be designed to be subordinate to the overall building composition.

- Internal illumination of an entire sign panel is discouraged. If internal illumination is used, a system that backlights sign text only is preferred.
- Neon and other tubular illumination may be considered. However, use neon in limited amounts so it does not become visually obtrusive.

14. Signs that are out of character with those seen historically, and that would alter the historic character of the street, are inappropriate.

15. Sign materials should be compatible with that of the building facade.

- Painted wood and metal are appropriate materials for signs. Their use is encouraged. Unfinished materials, including unpainted wood, are discouraged because they are out of character with the historic context.
- Highly reflective materials that will be difficult to read are inappropriate.



Where several businesses share a building, coordinate the signs in a directory or use a master sign plan



The overall façade composition including ornamental details and signs should be coordinated

16. Symbol and logo signs are encouraged.

- Symbol signs add interest to the street, are quickly read and are remembered better than written words.

17. Use colors for the sign that are compatible with those of the building front.

Policy: An awning should be similar in form to those seen traditionally in the downtown area

B. Awnings

Awnings and canopies have a long-standing tradition in the community and have been used to shelter sidewalks and shade display windows. Upper story awnings also have precedence and may be used. While awnings are relatively temporary placements, they can significantly affect one's ability to interpret the character of historic buildings. They can provide interest to pedestrians. Therefore, the thoughtful design of awnings and canopies is important.

1. An awning should be subordinate to the overall building composition.

- Awnings should be attached above the display windows and below the cornice or sign panel or transom and should not cover 2nd floor windowsills.
- Awning installation should not require the removal of or cover significant architectural features.
- Awnings should be mounted so that the valance is a minimum of eight feet above the sidewalk and projects no more than 6-1/2 (6'-6") feet from the building.

2. A simple awning is preferred.

- Aluminum, modern, or back lit awnings detract from the character and should not be erected.
- Avoid bright or intrusive colors that are dissimilar to the building's materials.

3. Awnings should not be installed where they will interfere with or cover decorative architectural details.

4. Installation should not damage surrounding materials.

5. Awnings should be sized to fit the size and shape of the opening.

6. Awnings should be constructed of canvas or similar woven material.

7. Operable awnings are encouraged.

- Use colors that are compatible with the overall color scheme of the facade. Solid colors or simple muted striped patterns may be appropriate.
- Awnings that obscure character-defining elements are inappropriate.

8. Mount an awning or canopy to accentuate character-defining features.

- Awnings should be mounted to highlight moldings that may be found above the storefront and should not hide character-defining features.
- Awning mountings should not damage significant features and historic details.
- Awnings that will be long in length should be divided into bays to reflect the storefront configuration.



This awning utilizes material compatible with its exterior, Spanish Tile.

Policy: Awning materials should be similar to those used traditionally in the downtown area.

9. An awning that is compatible with the material and style of a building is encouraged.

- Operable awnings are encouraged on historic buildings.
- Use colors that are compatible with the overall color scheme of the façade. Solid colors or simple, muted-stripe patterns are appropriate.

10. Internal illumination of an awning is inappropriate.

- Lights may be concealed below the awning to provide for pedestrian illumination to address safety, if these are oriented downward toward the sidewalk.



Awning accentuates the main entrance to a building.

Policy : Minimize the visual impacts of exterior lighting.

C. Lighting

The character and level of lighting that is used on a building is a special concern. Traditionally, these exterior lights were simple in character and were used to highlight signs, entrances, and first floor details. Most fixtures had incandescent lamps that cast a color similar to daylight, were relatively low in intensity and were shielded with simple shade devices. Preserve original light fixtures on buildings. If replacement is necessary, use fixtures appropriate to the period of the building.

1. Use lighting for the following:

- To accent architectural details,
- To accent building entrances,
- To accent signs, and
- To illuminate sidewalks.

2. Minimize the visual impacts of site and architectural lighting.

- All exterior light sources should have a low level of luminescence. White lights

that cast a color similar to day-light are preferred.

- Lighting fixtures should be appropriate to the building and its surroundings in terms of style, scale, and intensity of illumination.

3. Prevent glare by using shielded and focused light sources.

- Provide shield and focused light sources that direct light downward.
- Unshielded, high intensity light sources and those that direct light upward should not be permitted.
- Shield lighting fixtures associated with service areas, parking lots, and parking structures

Policy : Minimize the visual impacts of mechanical equipment and Service.

D. Utility and Mechanical Equipment

Utility service boxes, telecommunication devices, cables, and conduits are among the variety of equipment that may be attached to a building which can affect the character of the area. Trash and recycling storage areas also are concerns. To the greatest extent feasible, these devices should be screened from public view.

When screening one of the following methods can be used:

- The use of low-profile mechanical equipment;
- The use of screening (fence or wall made of compatible material);
- The location of the equipment (roof or less visible location); and
- The ability to paint the equipment to assist in camouflaging the equipment.

1. Minimize the visual impact of mechanical equipment on the public view when possible.

- Do not locate window air conditioning units on the building's primary façade.
- Use low-profile mechanical units on rooftops that are not visible from the public's view.

- Locate a satellite dish out of public view, to the extent feasible, and in compliance with other regulations.

2. Minimize the visual impacts of utility connections and service boxes.

- Locate these fixtures on secondary walls, whenever feasible.
- Do not locate gas or electric meters on the roof.

3. Minimize the visual impacts of trash storage and service areas.

- Locate service areas away from major pedestrian routes.



Good use of screening.

Policy: Minimize the visual impacts of parking lots.

E. Parking Facilities

New parking facilities should be designed to be attractive, compatible additions, to the Lee District. Using high quality materials, providing a sense of scale in architectural details and providing active uses at the sidewalk and street edge and landscaping are some methods that contribute to compatibility. Assistance for the development of parking facilities can be obtained at the City Development Services Department. In general, parking facilities should be designed to enhance the activity of the streetscape. The visual impact of the cars themselves should be minimized.

- 1. Locate a parking facility, particularly surface parking lots at the interior of a block whenever possible.**
 - This acknowledges the special function of corner properties as they are generally more visible than interior facilities, serve as landmarks and provide a sense of enclosure to an intersection
- 2. Where a parking facility shares a site with a building, place the parking at the rear of the site or beside the building.**
 - In this way, the architectural continuity of the street can be preserved.
 - Site a parking lot so it will minimize gaps in the continuous building wall of a block. A parking facility located behind a building and accessed from an alley is the preferred configuration.
- 3. Minimize disruption to the visual continuity of a street.**
 - Widths of entries to parking facilities should be minimized.
 - Where parking facilities interrupt the pattern of building facades on the street, the entry creating the break in the façade shall be minimized.

- 4. Provide well-lit and convenient pedestrian access to all parking facilities.**
 - Where new or renovated parking facilities interrupt existing patterns of pedestrian circulation, provide safe pedestrian routes through the site.
 - Maintain strong emphasis on the pedestrian environment at the sidewalk crossing of parking access points.
- 5. Reduce the visual impact of a large parking facility by dividing it into smaller facilities through the use of landscaping.**
- 6. Where a parking facility abuts a public sidewalk, provide a buffer.**
 - This may be a landscaped strip or planter.
 - Consider the planting of shrubs, vines and small trees of at least four feet in height, which can aid in the circulation of pedestrians and vehicles by demarcating boundaries and aisles and drawing attention to desired openings and paths for pedestrians.
 - Also consider the use of fences and walls as screens for the edges of facilities. Materials selected for barriers should be complementary to the character and materials of nearby historic buildings.
- 7. Integrate a parking facility with adjacent land uses.**
 - Accomplish this by using materials similar to those that are predominant in the area.
 - Use parking signs that are compatible with the City of Salina signage program.

Policy: Minimize the visual impacts of parking lots (continued)

- 8. Design a parking facility so that there is quick access and clear, separate pedestrian routes to the outside.**
 - Direct connections between a parking structure and its supporting businesses are desirable.
 - Interior and exterior lighting should be planned to assure user safety.
 - Encourage pedestrian use of the street front access and observation points by providing pedestrian facilities.
 - Develop mixed-use nodes of activity (such as espresso stands or other small vending kiosks or cafes) near pedestrian entries to parking areas.
 - Maximize visibility of pedestrians within the facility and avoid creation of dimly lit or isolated areas.
- Service and storage functions should be located away from the street edge and generally should not be visible from the street.
- 9. Encourage installation of bike racks in covered well-lit, publicly visible areas.**
- 10. Encourage landscaping areas and trees be integrated into built projects.**
 - This could be done:
 - As part of the building structure
 - On the roof
 - Adjacent to public right-of-way areas where allowed

Policy: Landscaping should be used to enhance the area.

F. Landscaping

Landscaping in the downtown should be used to enhance the area and to assist in obscuring mechanical equipment and parking areas. Architectural features should not be covered.

- A. Do not conceal or obscure the ground level of a building with landscaping.**
- B. Use landscaping trees and shrubbery listed on an approved list developed by the City Forester.**
- C. Preserve original retaining walls and fences where they exist.**

Chapter 6. Guidelines for Demolition

Essential Principles

Demolition is defined as the complete or partial tearing down or removal of a building, object, or structure within the Lee District.

Generally, the demolition of a building, which contributes historically or architecturally to the character and significance of the district is inappropriate and should be avoided.

Should the Design Review Board deem a proposed demolition appropriate, such demolition should proceed only when some reuse of the property is planned, unless it has been considered a safety hazard. A site restoration plan*, including any plans for redevelopment or new construction on the site, if proposed, should be submitted to and reviewed by the DRB in conjunction with the submission and review of the proposed demolition.

Any proposed demolition includes appropriate grading to a mowable, maintainable condition and seeding or landscaping of the building site in a manner compatible with the adjoining buildings and landscape.

Guidelines for Proposed Demolition

Demolition should only be considered under any of the following conditions:

1. If the City Building Official has ordered demolition for the public safety because of an unsafe or dangerous condition which constitutes an emergency;

2. If a building, object, or structure: a) does not contribute to the historical or architectural character and b) detracts from and does not have the potential to contribute to the importance of the District and c) its removal and the proposed site restoration plan, including any plans for new construction on the site, will result in a more positive, appropriate visual effect on the District.

Demolition should not be considered under any of the following conditions:

1. If a building, object or structure is of significance that its removal would be detrimental to the public interest and the objectives of the District;
2. If a building, object, or structure is of such architectural or historic character that it could not be reproduced without great difficulty and expense;
3. If its proposed reuse, or new construction would make a less positive visual contribution to the District, would disrupt the character of the District, or would be visually incompatible; or
4. If the demolition of a building, object, or structure would negatively impact the character, streetscape, or other buildings, objects, or structures in the District.

* A site restoration plan may consist of a written narrative or set of specifications in lieu of a site plan drawing

Chapter 7. Guidelines for Relocation

Essential Principles

The definition of the relocation of a building is the concept of moving a building into the Lee District or from one site to another within the District. Removal of a building, object, or structure from the District shall be considered and reviewed as a demolition of the building, object, or structure. Moving an existing building which still retains architectural and historical integrity and which contributes to the architectural and historical character of the District should be avoided.

Moving a building which does not contribute to the historical and architectural integrity of the District or which has lost architectural integrity due to deterioration and neglect is appropriate if its removal or the proposal for its replacement will result in a more positive appropriate visual effect on the District.

Guidelines for Relocation

Relocated buildings must be carefully rebuilt to retain and maintain original architectural details and materials.

A building may be moved into the District if it maintains a sense of architectural unity in terms of style, height, scale, massing, materials, quality of construction, and texture with the existing District.

A building may be moved from one site to another in the District if:

1. The integrity of location and setting of the building in its original location has been lost or is seriously threatened;
2. The new location will be similar in setting and siting;
3. The building will be compatible with the buildings, adjacent to the new location in style, height, scale, materials, and setback;
4. The relocation of the building will not result, in the Board's reasonable discretion, in a negative visual impact on the site and surrounding buildings from which it will be removed.

Design Guidelines for Downtown Salina Appendices

Certificate of Compatibility Design Matrix

The Lee District is recognized as a special place to be protected as a community resource, because it represents an important part of the city's heritage, and because its unique character creates an identity for Salina today. Using compatible design for exterior improvements helps to enhance the quality of life for the city's residents while strengthening the economic vitality of its Downtown. The Lee District Design Review Board reviews exterior building and sign projects to encourage visual harmony, to enhance historic integrity and to encourage creative design solutions.

The Design Review Board (DRB) uses the adopted *Design Guidelines for Downtown Salina* for project review. The guidelines do not dictate specific architectural styles, but suggest a variety of choices for achieving design compatibility within the Downtown area. The guidelines also help to protect property values by encouraging improvements that conserve and maintain existing buildings as viable community assets for the future. To facilitate this, the Design Review Board issues *Certificates of Compatibility* for planned construction, alteration or demolition projects that would result in a permanent physical change to buildings, structures or sites within the Lee District.

Routine maintenance or repair, where there is no change made to the design, material, color or general appearance of a feature, does not require a review by the DRB.

The City Development Services Department provides administrative assistance to the Design Review Board. The Development Services Department receives completed applications for Certificates of Compatibility, provides legal notice for public hearings and coordinates approved Certificates of Compatibility with the City Building Services Division for the issuance of building or sign permits. The nature and scope of projects submitted for design review often vary in complexity and scale. When an application is submitted, Development Services staff makes a determination of the scope of a project. Projects that involve *Minor Work* can generally be reviewed and approved by administrative staff. Projects that involve *Major Work* will be scheduled for a public hearing before the Design Review Board. The Board meets on the second, fourth and fifth Thursdays of each month at 4:00 in Room 107 of the City-County Building, 300 West Ash Street.

The Downtown design review procedures are as follows:

- **Minor Work projects are reviewed by Development Services staff. The processing time for applications is generally 2-3 days, if an application is complete.**

Minor Work review is required for those projects in which the visual character of the structure or site is not substantially changed. Minor work applications may be submitted at any time. Applicants are encouraged to consult with Development Services staff early in the design stage for a project to determine the level of review and the information that will be required with submittal of a Certificate of Compatibility application.

- **Major Work projects are reviewed by the Design Review Board at a public hearing. The processing time for applications is generally 14 days, if an application is complete.**

The Design Review Board reviews major projects at a scheduled public hearing. The deadline for submitting applications is 5:00 PM 14 days before a regularly scheduled meeting. Legal notification is sent to adjacent property owners stating the time and place for the meeting. Applicants are encouraged to consult with Development Services staff early in the design stage of a project to determine the level of review and the information that will be required with submittal of a Certificate of Compatibility application.

The following pages contain a listing of common project types and the degree of review that is required for an application. This listing is not meant to be all inclusive and there may be project types that are not listed on the form. An applicant is responsible for consulting with Development Services staff in order to determine what type of project review may be required and the time frame for submission of applications.

DESIGN REVIEW PROJECT

TYPE OF REVIEW REQUIRED

	TYPE OF WORK	MINOR WORK (Minor Review)	MAJOR WORK (Full Review)
1	Replacement of door and window hardware	X	
2	Replacement of an existing awning or canopy with a new awning or canopy (without signage)	X	
3	New awnings without signage	X	
4	Window or wall signs less than 2 sq. ft.	X	
5	Window or wall signs greater than 2 sq. ft.		X
6	Sidewalk signs, temporary signs	X	
7	Alteration/ addition or removal of doors or windows		X
8	New awnings or canopies with signage		X
9	New projecting signs; pole signs or ground signs		X
10	New exterior decks/stairs; Exterior stair replacement		X
11	New fencing, walls or screening		X
11	Demolition/relocation of principal structures		X
12	Demolition/relocation of accessory structure		X
13	New principal structure on a property		X
14	New accessory structure on a property		X
15	Repair or replacement of architectural features using the same design, materials and same general appearance to the original condition.	X	
16	Site modification on private property (parking, driveways, curbing, walkways etc.)		X
17	Exterior repainting		X
18	Building additions		X
19	Minor storefront alterations: Projects that are less than \$1,000 in cost, or that do not substantially alter existing features	X	

20	Major storefront alterations: Projects greater than \$1,000 in cost, or that do substantially alter existing features		X
21	Removal of mechanical equipment, electrical and plumbing equipment from site exterior.	X	
22	Emergency repair when applied on a temporary basis to prevent further loss or harm to existing features	X	
23	Routine Maintenance, when there is no change in the design, material, color or general appearance of a feature (i.e., painting buildings or windows with the same color)	No review needed	No review needed

Appendix II. Glossary of Architectural Terms

- Adaptive Use:** Rehabilitation of an historic structure for use other than its original use such as a residence converted into offices.
- Alignment:** The arrangement to objects along a straight line.
- Alteration:** Work which impacts any exterior architectural feature including construction, reconstruction, repair, or removal of any building element.
- Appurtenances:** An additional object added to a building; typically included vents, exhaust hoods, air conditioning units, etc.
- Arch:** A curved construction of wedge shaped stones or bricks which spans an opening and supports the weight above it. (see flat arch, jack arch, segmental arch and semi-circular arch)
- Baluster:** One of a series of short, vertical, often vase-shaped members used to support a stair or porch handrail, forming a balustrade.
- Balustrade:** An entire rail system with top rail and balusters.
- Bay:** The portion of a facade between columns or piers providing regular divisions and usually marked by windows.
- Belt course:** A horizontal band usually marking the floor levels on the exterior facade of a building.
- Bond:** A term used to describe the various patterns in which brick (or stone) is laid, such as "common bond" or "Flemish bond".
- Bracket:** A projecting element of wood, stone, or metal which spans between horizontal and vertical surfaces (eaves, shelves, overhangs) as decorative support.
- Bulkhead:** The structural panels just below display windows on storefronts. Bulkheads can be both supportive and decorative in design. Nineteenth century bulkheads are often of wood construction with rectangular raised panels. Twenty Century bulkheads may be of wood, brick, tile, or marble construction. A bulkheads is sometimes referred to as a kickplate.
- Capital:** The head of a column or pilaster.
- Casement window:** A window with one or two sashes which are hinged at the sides and usually open outward.
- Certificate of Compatibility:** A document issued by the Design Review Board allowing an applicant to proceed with a proposed alteration, demolition, or new construction in a designated area or site following a determination of the proposal's suitability according to applicable criteria.
- Character-defining feature:** A prominent or distinctive aspect, quality, or characteristic of a historic property that contributes significantly to its physical character.
- Column:** A circular or square vertical structural member.
- Common bond:** A brickwork pattern where most courses are laid flat, with the long "stretcher" edge exposed, but every fifth or eighth course is laid perpendicularly with the small "header" end exposes, to structurally tie the wall together.
- Configuration:** The arrangement of elements and details on a building or structure which help to define its character.
- Contemporary:** Reflecting characteristics of the current period. Contemporary denotes characteristics, which illustrate that a building, structure, or detail was constructed in the present or recent past rather than being imitative or reflective, or an historic design.
- Contributing Structure:** A structure that contributes to the historic character of a district.
- Corbel:** In masonry, a projection, or one of a series of projections, each stepped progressively farther forward with height and articulating a cornice or supporting an overhanging member.
- Cornice:** The uppermost, projecting part of an entablature, or feature resembling it. Any projecting ornamental molding along the top of a wall, building, etc.
- Dentils:** A row of small tooth-like blocks in a classical cornice.
- Design Guidelines:** Criteria developed by the community and the Design Review Board to identify design concerns in an area and to help property owners ensure that rehabilitation and new construction respect

the character of historic buildings and the Lee District.

Designated Historic Structure: Any structure that is: 1) Listed individually in the National/State Register of Historic Places or preliminarily determined by the Secretary of the Interior as meeting the requirements for individual listing on the National Register; 2) Certified or preliminarily determined by the Secretary of the Interior as contributing to the historical significance of a registered district or a district preliminarily determined by the Secretary to qualify as a registered historic district; 3) Individually listed on a state inventory of historic places; or 4) Individually listed on a local inventory of historic places.

DRB: Lee District Design Review Board.

Double-hung window: A window with two sashes, one sliding vertically over the other.

Downtown Salina: That area previously encompassed by the Business Improvement District No. 1, now renamed the "Lee District".

Due process: The established procedure by which legal action is carried out.

Eave: The edge of a roof that projects beyond the face of a wall.

Element: A material part or detail of a site, structure, street, or district.

Elevation: Any one of the external faces or facades of a building.

Engaged column: A round column attached to a wall.

Entablature: A part of a building of classical order resting on the column capital; consists of an architrave, frieze, and cornice.

Fabric: The physical material of a building, structure, or community, connoting an interweaving of component parts.

Façade: The elevation of a building that is visible from a public or private right-of-way.

Fascia: A flat board with a vertical face that forms the trim along the edge of a flat roof, or along the horizontal, or "eaves," sides of a pitched roof. The rain gutter is often mounted on it.

Fenestration: An opening in a structure, such as a door or window.

Flat arch: An arch whose wedge-shaped stones or bricks are set in a straight line; also called a jack arch.

Flemish bond: A brickwork pattern where the long "stretcher" edge of the brick is alternated with the small "header" end for decorative as well as structural effectiveness.

Fluting: Shallow, concave grooves running vertically on the shaft of a column, pilaster, or other surface.

Form: The overall shape of a structure.

Foundation: The lowest exposed portion of the building wall, which supports the structure above.

Frieze: The middle portion of a classical cornice; also applied decorative elements on an entablature or parapet wall.

Gable: The triangular section of a wall to carry a pitched roof.

Gable roof: A pitched roof with one downward slope on either side of a central, horizontal ridge.

Ghosts: Outlines or profiles of missing buildings or building details. These outlines may be visible through stains, paint, weathering, or other residue on a building's facade.

Glazing: Fitting glass into windows and doors.

Head: The top horizontal member over a door or window opening.

Hipped roof: A roof with uniform slopes on all sides.

Historic Structure: Any property that is 50 years in age, that retains integrity to its original design and that is representative of its period of historic significance.

Historic District: A geographically definable area with a significant concentration of buildings, structures, sites, spaces, or objects unified by past events, physical development, design, materials, workmanship, sense of cohesiveness, or related historical and aesthetic associations. The significance of a district may be recognized through listing in a local, state, or national landmarks register.

- Historic Imitation:** New construction or rehabilitation where elements or components mimic an architectural style but are not of the same historic period as the existing buildings (i.e. historic replica).
- Hood molding:** A projecting molding above an arch, doorway, or window, originally designed to direct water away from the opening; also called a drip mold.
- Infill:** New construction on vacant lots or to replace existing buildings.
- Jack arch:** (see Flat arch)
- Keystone:** The wedge-shaped top or center member of an arch.
- Landmark:** A building, structure, object or site which is identified as a historic resource of particular significance.
- Lintel:** The horizontal top member of a window, door, or other opening.
- Masonry:** Exterior wall construction of brick or stone laid up in small units.
- Massing:** The three-dimensional form of a building.
- Material:** Refers to the physical elements that were combined or deposited in a particular pattern or configuration to form a historic property.
- Material Change:** A change that will affect either the exterior architectural or environmental features of an historic property or any structure or site.
- Module:** The appearance of a single façade plane, despite being part of a larger building. One large building can incorporate several building modules.
- Modillion:** A horizontal bracket, often in the form of a plain block, ornamenting, or sometimes supporting, the underside of a cornice.
- Molding:** A decorative band or strip of material with a constant profile or section designed to cast interesting shadows. It is generally used in cornices and as trim around window and door openings.
- Mortar:** A mixture of sand, lime, cement, and water used as a binding agent in masonry construction.
- Mullion:** A heavy vertical divider between windows or doors.
- Multi-light window:** A window sash composed of more than one pane of glass.
- Muntin:** A secondary framing member to divide and hold the panes of glass in multi-light window or glazed door.
- Normally Required:** Mandatory actions, summarized in the guidelines, whose compliance is enforced by the preservation commission.
- Obscured:** Covered, concealed, or hidden from view.
- Orientation:** Generally, orientation refers to the manner in which a building relates to the street. The entrance to the building plays a large role in the orientation of a building; whereas, it should face the street.
- Paneled door:** A door composed of solid panels (either raised or recessed) held within a framework of rails and stiles.
- Parapet:** A low horizontal wall at the edge of a roof.
- Pediment:** A triangular crowning element forming the gable of a roof; any similar triangular element used over windows, doors, etc.
- Pier:** A vertical structural element, square or rectangular in cross-section.
- Pilaster:** A square pillar attached, but projecting from a wall, resembling a classical column.
- Pitch:** The degree of the slope of a roof.
- Portland cement:** A strong, inflexible hydraulic cement used to bind mortar. Portland cement is harder than the masonry, thereby causing serious damage over annual freeze-thaw cycles and should not be used on old buildings.
- Post:** A piece of wood, metal, etc., usually long and square or cylindrical, set upright to support a building, sign, gate, et.; pillar; pole.
- Preservation:** The act of maintaining the form and character of a building as it presently exists. Preservation stops deterioration and stabilizes the structure. Generally, saving from destruction or deterioration old and historic buildings, sites, structures, and objects and providing for their continued use by means of restoration, rehabilitation, or adaptive use.

- Pressed tin:** Decorative and functional metalwork made of molded tin used to sheath roofs, bays, cornices or ceilings.
- Proportion:** Harmonious relation of parts to one another or to the whole.
- Quoins:** A series of stone, bricks, or wood panels ornamenting the corners of a building.
- Reconstruction:** The act or process of reproducing by new construction the exact form and detail of a vanished building, structure, or object, or a part thereof, as is appeared to its historical, architectural, and cultural values.
- Rehabilitation:** The act or process of returning a property or building to usable condition through repair, alteration, and/or preservation of its features which are significant to its historical, architectural, and cultural values.
- Repair:** Returning a structural, nonstructural or decorative building element to a state of utility by using matching or identical material to the original.
- Restoration:** The act or process of accurately taking a building's appearance back to a specific period of time by removing later work and by replacing missing earlier features to match the original.
- Rhythm:** Movement or fluctuation marked by regular occurrence or natural flow of related elements.
- Ridge:** The top horizontal member of a roof where the sloping surfaces meet.
- Routine Maintenance:** The restoration or repair of a feature or element where there is no change made to the design, material, color, profile or general appearance of a building feature. The replacement of a severely deteriorated feature utilizing material that matches the original to the greatest extent possible.
- Rusticated:** Roughening of stonework of concrete blocks to give greater articulation to each block.
- Sash:** The moveable framework containing the glass in a window.
- Segmental arch:** An arch whose profile or radius is less than a semicircle.
- Semi-circular arch:** An arch whose profile or radius is a half-circle the diameter of which equals the opening width.
- Shed roof:** A gently-pitched, almost flat roof with only one slope.
- Sidelight:** A vertical area of fixed glass on either side of a door or window.
- Significant:** Having particularly important association within the contexts of architecture, history, and culture.
- Sill:** The bottom crosspiece of a window frame.
- Stabilization:** The act or process of applying measures essential to the maintenance of a deteriorated building as it exists at present, establishing structural stability and a weather-resistant enclosure.
- Stile:** A vertical piece in a panel or frame, as of a door or window.
- Streetscape:** The distinguishing character of a particular street as created by its width, degree of curvature, paving materials, design of the street furniture, and forms of surrounding buildings.
- Style:** A type of architecture distinguished by special characteristics of structure and ornament and often related in time; also a general quality of distinctive character.
- Surround:** A encircling border or decorative frame, usually at windows or doors.
- Transom:** A horizontal opening (or bar) over a door or window. (see Overlight)
- Trim:** The decorative framing of openings and other features on a facade.
- Visual Continuity:** A sense of unity or belonging together that elements of a built environment exhibit because of similarities among them.

Appendix III

Secretary of Interior's Standards for Rehabilitation

The Secretary of the Interior's Standards for Rehabilitation were developed for use in review of all federal projects which would affect historic properties listed or eligible for listing in the National Register. A now frequent application of the Standards is in determining if a rehabilitation project qualifies as a "certified rehabilitation". For this, the Secretary is required to verify that the rehabilitation is "consistent with the historic character of the structure or the district in which it is located". Certified projects can be eligible for the State or Federal Rehabilitation Tax Credit Program.

The list of ten Rehabilitation Standards is aimed at retaining and preserving those architectural features and materials which are important in defining the historic character of a building or site. The Standards have gained wide usage as many cities and counties around the country have adopted the standards to promote historic rehabilitation and adaptive use of historic structures.

- 1) A property shall be used for its historic purpose or be placed in a new use that requires minimal change to the defining characteristics of the building and its site and environment.
- 2) The historic character of a property shall be retained and preserved. The removal of historic materials or alteration of features and spaces that characterize a property shall be avoided.
- 3) Each property shall be recognized as a physical record of its time, place and use. Changes that create a false sense of historical development, such as adding conjectural features or architectural elements from other buildings, shall not be undertaken.
- 4) Most properties change over time; those changes that have acquired historic significance in their own right shall be retained and preserved.
- 5) Distinctive features, finishes, and construction techniques or examples of craftsmanship that characterize a historic property shall be preserved.
- 6) Deteriorated historic features shall be repaired rather than replaced. Where the severity of deterioration requires replacement of a distinctive feature, the new feature shall match the old in design, color, texture, and other visual qualities and, where possible, materials. Replacement of missing features shall be substantiated by documentary, physical or pictorial evidence.
- 7) Chemical or physical treatments, such as sandblasting, that cause damage to historic materials shall not be used. The surface cleaning of structures, if appropriate, shall be undertaken using the gentlest means possible.
- 8) Significant archaeological resources affected by a project shall be protected and preserved. If such resources must be disturbed, mitigation measures shall be undertaken.

- 9) New additions, exterior alterations, or related new construction shall not destroy historic materials that characterize the property. The new work shall be differentiated from the old and shall be compatible with the massing, size, scale, and architectural features to protect the historic integrity of the property and its environment.
- 10) New additions and adjacent or related new construction shall be undertaken in such a manner that if removed in the future, the essential form and integrity of the historic property and its environment would be unimpaired.

Appendix IV. Preservation Briefs

The National Park Service Technical Preservation Services has published a series of technical bulletins providing illustrated easy to read guidance on preserving, rehabilitating and restoring historic buildings. The bulletins are updated periodically To order hard copies of the Briefs from Technical Preservation Services see the links at the end of this section. Free on-line copies of the Briefs and other technical bulletins are available.

- 1: The Cleaning and Waterproof Coating of Masonry Buildings.
- 2: Repointing Mortar Joints in Historic Brick Buildings.
- 3: Conserving Energy in Historic Buildings.
- 4: Roofing for Historic Buildings.
- 6: Dangers of Abrasive Cleaning to Historic Buildings.
- 7: The Preservation of Historic Glazed Architectural Terra-Cotta.
- 8: Aluminum and Vinyl Siding on Historic Buildings: The Appropriateness of Substitute Materials for Resurfacing Historic Wood Frame Buildings.
- 9: The Repair of Historic Wooden Windows.
- 10: Exterior Paint Problems on Historic Woodwork.
- 11: Rehabilitating Historic Storefronts.
- 12: The Preservation of Historic Pigmented Structural Glass (Vitrolite and Carrara Glass).
- 13: The Repair and Thermal Upgrading of Historic Steel Windows.
- 14: Exterior Additions to Historic Buildings: Preservation Concerns.
- 15: Preservation of Historic Concrete: Problems and General Approaches.
- 16: The Use of Substitute Materials on Historic Building Exteriors.
- 17: Architectural Character - Identifying the Visual Aspects of Historic Buildings as an Aid to Preserving Their Character.
- 22: The Preservation and Repair of Historic Stucco.
- 24: Heating, Ventilating, and Cooling Historic Buildings: Problems and Recommended Approaches.
- 25: The Preservation of Historic Signs.
- 29: The Repair, Replacement, and Maintenance of Slate Roofs.
- 30: The Preservation and Repair of Historic Clay Tile Roofs.
- 31: Mothballing Historic Buildings.
- 32: Making Historic Properties Accessible.
- 33: The Preservation and Repair of Stained and Leaded Glass.
- 35: Understanding Old Buildings: The Process of Architectural Investigation.
- 38: Removing Graffiti from Historic Masonry.

- 39: Holding the Line: Controlling Unwanted Moisture in Historic Buildings.
- 40: Preserving Historic Ceramic Tile Floors.
- 41: The Seismic Retrofit of Historic Buildings.
- 42: The Maintenance, Repair and Replacement of Historic Cast Stone.
- 43: The Preparation and Use of Historic Structure Reports.
- 44: The Use of Awnings on Historic Buildings.

Copies of the Briefs are available at:

City of Salina, Development Services Department, 300 W. Ash Street, Room 201, Salina, Kansas 67402 785-309-5720

U.S. Government Printing Office, 732 N. Capitol Street, NW Washington, DC 20401
Toll-Free: 866-512-1800 <http://bookstore.gpo.gov/>

To download *free on-line copies* of the Briefs visit: National Park Service, Technical Preservation Services Department: <http://www.nps.gov/history/hps/tps/tpscat.htm>